

Things that blink: Computationally augmented name tags



by R. Borovoy
M. McDonald
F. Martin
M. Resnick

The conventional name tag automatically dispenses information at a time when it is useful and relevant. The name of the person wearing the tag is visible in a face-to-face encounter. The information presented on a name tag changes according to who is wearing the name tag, but it does not depend on who is viewing the name tag. This paper presents a computationally augmented name tag—the “Thinking Tag”—that is capable of displaying different information depending on who is viewing it. When two participants at an event face each other, their name tags change to reflect a simple measure of how much they have in common. A goal of the Thinking Tag technology design is to create an augmented name tag that does not interfere with the social mechanisms that normally operate among groups of people. Therefore, the communication and computation technology are hidden within the tag.

In celebration of the MIT Media Laboratory's tenth birthday and for the launch of the Things That Think consortium, visitors from around the world came to MIT to attend lectures and view demonstrations.

As is customary, upon arriving at the lab, visitors received name tags. In addition to displaying the visitor's name and affiliation, however, these computational “Thinking Tags” were capable of telling the visitors how much they had in common with the people they encountered.

Visitors considered five multiple-choice questions, and programmed their answers into their Thinking Tags. Whenever two people came face-to-face, their tags exchanged data. Each tag had five light-emitting diodes (LEDs); for each question that the two people

answered the same, one LED would light green. For each question where they disagreed, one LED would light red.

Adding computational power to a traditional name tag augments its ability to provide useful information in a proximal interpersonal interaction. Although a significant portion of the design focus for the Thinking Tag project involved the technological issues surrounding tag construction, communication, and personalization, most of the work in implementing the project actually involved understanding and preserving the original nature and social dynamics of name tags.

This paper provides a detailed description of the Thinking Tag system from the perspective of both the user and the system designer.

User perspective

When visitors arrived at the Media Lab to register for the Things That Think meeting, they were given a Thinking Tag and directed to the programming booths, which were distributed around the lobby with buckets hanging from them. The visitors read the questions posted on the booths and then programmed the answer of their choice by dunking their tags into the bucket corresponding to their choice.

©Copyright 1996 by International Business Machines Corporation. Copying in printed form for private use is permitted without payment of royalty provided that (1) each reproduction is done without alteration and (2) the *Journal* reference and IBM copyright notice are included on the first page. The title and abstract, but no other portions, of this paper may be copied or distributed royalty free without further permission by computer-based and other information-service systems. Permission to *republish* any other portion of this paper must be obtained from the Editor.

Five questions were chosen to reflect technological issues addressed by the Media Lab while encouraging people to think about how technology affects their personal lives. For example, the question, “Which of these ‘Things That Think’ would you want most?” asks people to make a personal decision about which possible advances in technology would mean the most to them. Figure 1 shows the complete text of the five questions selected.

The Thinking Tags were programmed at a series of five stations, one corresponding to each question. At each station, the question was posted on top, and three buckets hung below (see Figure 2). Each bucket corresponded to one of the three possible answers to the question. At the bottom of each bucket was a programming beacon that would set the given answer into the Thinking Tag’s memory. The bucket made a beeping noise to signal that the answer had been successfully programmed into the tag, and then the participant proceeded to another station to answer the next question.

Related research

The Thinking Tag project is situated in the research traditions of computer-supported cooperative work, computational badges, and context personalization.

Computer-supported cooperative work. Because the Thinking Tag technology is used to support social processes, it is an example of computer-supported cooperative work. Research in this domain can be categorized by how much the technology pervades the social interaction. At one end of this spectrum is technology that becomes the dominant medium for human interaction. Virtual reality environments such as MUDs (Multi-User Dungeons) are located on this extreme, since all human interaction in a MUD is mediated through the keyboard and text-based display.¹ Meeting-support environments like Xerox Collab are in the middle of this spectrum. Large, whiteboard-sized displays mediate much of the interaction, but traditional face-to-face exchanges are also an important part of the environment.² Thinking Tags are on the opposite side of the spectrum from MUDs. Rather than interpersonal communication *flowing through* the technology, Thinking Tags “add spice” to the traditional conversational exchange.

Computational badge technology. The Thinking Tag project applies computational badge technology to name tags. Other systems focus on how portable

Figure 1 The five questions used for the Thinking Tag event

How would you like to spend your “15 minutes of fame”?

- A. Profile in *The New York Times*
- B. Interview with Oprah Winfrey
- C. Hyperlink off main page of Yahoo

In the future, you will see more advertising because

- A. Ads will be useful and interesting
- B. Ads will be unavoidable
- C. You won't see more ads—you'll pay for content

Which of these “Things That Think” would you want most?

- A. Universal translator that fits in your ear
- B. Violin that can teach you to play
- C. Mood rings that can transmit your emotions

Who would you most like to have dinner with?

- A. O. J. Simpson, Marcia Clark, and Johnnie Cochran
- B. Marvin Minsky, Noam Chomsky, and Jerome Lettvin
- C. Peter Gabriel, Laurie Anderson, and Yo-Yo Ma

What is your biggest fear about the future of the Internet?

- A. Loss of intellectual property
- B. Invasion of privacy
- C. Inequity of access

badges can interface people to machines, such as security systems for buildings. Those badges could determine their wearer’s location and identity, and were used for building automation and security functions, such as automatic call forwarding and door opening. They have also been used to provide information to building inhabitants about the location of one another via computer-generated maps; e.g., see Olivetti’s Active Badges as described in Want et al.³ Computationally active badges have not been used to augment the main function of a name tag—the face-to-face presentation of information about the wearer to another person.

Context personalization. Information personalization is not a new concept. Electronic newspapers, for example, attempt to provide users with news stories

Figure 2 Bucket programming stations



they most likely want to see—such as the stock prices of companies they invested in and the news from the town where they grew up. Personalization in this case refers to *filtering*, which has been the major direction for personalized information systems, both in research and in industry; e.g., see References 4 and 5.

Filtering, however, is not the only way to personalize information. An example of context personalization is the PLUM system,⁶ which takes news stories about natural disasters in faraway places and augments them with geographical information about the reader's hometown, providing people with a better understanding of the often cryptic statistics presented in articles.

The Thinking Tags are a different example of context personalization. The information contained in the Thinking Tag's memory is established by the bucket programming. That information is transmitted, without alteration, to other badge wearers. The actual personalization does not occur until a tag has received someone else's data. At that point, the tag transforms the information into a display relevant to both viewers.

Design rationale

Many objects have functionality that is taken for granted, which can easily be overlooked in the design

of augmented objects. This can result in designs that inadvertently sacrifice one functionality in an attempt to augment another.

The primary function of a name tag is to display information that is both useful and specific to the participants in a conversation. In order to successfully augment this functionality, the Thinking Tag should continue to be readily interpreted, easy to author, and comfortable to wear.

Participant-sensitive communication. Name tags encourage and support interaction between people by providing information relevant to the context of their conversation. To augment this functionality, Thinking Tags compute and display additional information that is potentially more useful in a conversation than just name and company: a simple measure of how much the viewer and wearer have in common. This information can function as an “ice breaker” between strangers and as a source of entertainment for people already acquainted.

We considered various ways for the Thinking Tag to display the affinity measure. One possibility was to have each LED on the badge correspond to a particular question, with an LED lit green when wearer and viewer answered in common, and one lit red when they disagreed. Mapping LEDs to specific questions

would not have encouraged conversations, since participants could discover what they had in common without ever talking to one another. Other display algorithms were tested but proved difficult to understand; discussions of interpretation frequently took over the conversation. Obviously, this was inappropriate for a technology trying to augment interaction.

Reminded of Don Norman's admonition, "Over and over again we find unwarranted complexity that could be avoided were the device to contain a good visual display,"⁷ a middle path was invented: light one LED green for each common answer and red for each different answer. These LEDs were to be sorted, so that all the greens appeared in series, followed by all the reds. This algorithm attempted to provide participants with enough information to pique their curiosity and encourage conversation without being confusing.

Linking name tag content to human context. In order to provide both viewer- and wearer-sensitive information, we had to augment the normal means for linking name tag content to human context. The context of the traditional printed name tag consists solely of its wearer; maintaining the contextual relevance of the name tag simply requires fixing it to the wearer.

Adding viewer sensitivity while not interfering with human interaction proved to be a design challenge. A protocol was designed by which one person's name tag would exchange information via an infrared signal with another person's and then display something that was personalized to each viewer.

The most difficult issue was ensuring that if two people were standing in front of each other, their two tags were also communicating. People should not have to spend time aiming their badges; nor should they have to be too close to each other. These antisocial activities would have violated the name tag's primary role of encouraging human interaction. Further, when two people were conversing, signals from tag wearers outside the conversation should not interfere. This could result in two people assuming their tags are personalized for each other, when in fact one of their tags is "talking" to another person in the general vicinity. Such an outcome would be a breakdown in context sensitivity.

The desire to get Thinking Tags to interact without aiming them or being too close demanded that the power and breadth of the infrared signal be increased; this was at odds with the desire to preclude interfer-

ence, which required that the power be reduced. We experimented with several different power levels and signal breadths and chose a suitable midpoint.

Easy personalization. Authoring the digital information for one's Thinking Tag had to be easy in order to meet users' expectations of name tags. One solution was to preprogram the badges with attendees' information, so that the Thinking Tag was ready to go when handed out. This solution would have entailed gathering these data (i.e., participants' answers to opinion questions) in advance, however, which was not very practical. Another option was to provide workstations where participants could key in their answers to questions displayed on a screen, but forcing someone into a several-minutes interaction with a cathode-ray tube immediately after entering the building did not seem very welcoming.

We hit upon the idea of letting people program their badges by "dunking" them in buckets that corresponded to their answers to various multiple-choice questions. This method seemed both easy and fun. It also took advantage of the embodied nature of the Thinking Tags by allowing them to be programmed in a three-dimensional spatial fashion. Most importantly, it fit in with the primary requirement that name tags support human interaction; people could stand around the buckets discussing the different questions and answers with one another. Programming one's Thinking Tag became a social event in itself.

Comfort and durability. Maintaining the required comfort and durability of a name tag while augmenting it with computation proved challenging. It is taken for granted that a traditional name tag will function over a two-day event and will be reasonably comfortable to wear. These requirements became serious design constraints when we considered the addition of technology.

The durability of the Thinking Tag and its comfort were at odds. The display required battery power; the longer the device was meant to operate, the bigger the battery that was necessary. Modest-sized, lightweight watch batteries that could last one or two days and be replaced if needed were chosen.

Even with careful design of the electronics, the Thinking Tag was heavier than a conventional name tag. This constraint was important to consider, since an uncomfortable name tag would not be worn. Because of the weight, stick pins would not be appropriate for

holding the tag because they could damage delicate clothing. Instead, rubber cords were selected, allowing the tag to be worn around the neck.

Future directions

The Thinking Tag developed for the Media Lab anniversary event just begins to demonstrate the opportunities for computational technology in social interaction.

An extension of the project would allow the tags to collect interactional data. These data could be used to describe and analyze the social patterns at an event. Tags would record the unique IDs of all the other tags that were encountered; the collective tag database then would be transferred to a central database for processing.

Once the information about who spoke with whom was collected from the individual tags, a variety of questions about group interactions could be answered: were there many “social butterflies” (i.e., people who interacted with a significant fraction of the whole group); how “cliqish” is the meeting (are there many internally highly interconnected but isolated sub-groups); how many people interacted with one or a few celebrities present? Various ways of visualizing this social intercourse could be developed. For instance, publicly viewable computer monitors would dynamically reflect these interpretations back to the group while the meeting was in progress.

One of several challenges associated with the data collection activities concerns participant privacy. A solution to this problem would be to separate participants’ names from their badge IDs. It would be difficult to identify people simply by the log of which other anonymous IDs they had interacted with. Performing the measure of interactions with a celebrity would need this person’s ID to be known, of course, but others’ identities could remain anonymous.

Another challenge would be the retrieval of data from the tags. The relatively low bandwidth of the communications technology would necessitate several seconds of data transfer. Requiring each person to explicitly upload data at the main database is not an appealing solution. A possible solution to this problem would be to have special tags worn by event facilitators that periodically polled normal tags for their interaction data. This data transfer would occur almost transparently to the tag wearer. After mingling

for a while, event facilitators would perform an explicit upload of the data they had collected.

A more sophisticated tag design would enable a wide range of applications. The next generation of tags will

The Thinking Tag demonstrates the opportunities for computational technology in social interaction.

include additional input modes (body and environmental sensors), output capabilities (an alphanumeric or graphical liquid crystal display [LCD] screen), and data-holding capabilities (name, company, and other information). Some additional applications include the use of tags to pass messages between people, to gauge the mood of tag wearers, and to exchange business-card information between conversation participants.

Conclusions

The Thinking Tag project demonstrates the design process that is required in building a “Thing That Thinks.” The most obvious properties of an object can be overlooked in an effort to provide enhanced computational functionality. It is important to preserve the natural qualities of an object while augmenting its capabilities.

Based on informal observations of the more than 200 attendees of the anniversary event, the Thinking Tags were successful as both name tags and conversation pieces. Almost all people wore them throughout the first day, for which their use was planned, and many wore them for a second day, stimulating conversation with a larger gathering of more than a thousand.

People learned how to program the Thinking Tags with minimal intervention. The method of dunking the tags into the colored buckets made enough sense that once a few people were shown how to do it, they were able to show people who subsequently arrived at the kiosks. This was a key design decision that, hav-

ing been made correctly, allowed people to use their tags in a fluent and effortless manner.

The personalized badges from Olivetti triggered a wave of new thinking in name tag technology, but they did not provide any enhanced information to the viewer of the name tag. Although the Thinking Tags currently only transmit a few bits of information, the future applications of the work extend beyond “ice breakers.” The social issues involved in communicating useful data without hindering the natural interaction of the wearers will become increasingly important as the field of wearable computing grows.

Acknowledgments

Brian Silverman was centrally responsible for the software design of the Thinking Tag system and also contributed to other aspects of the overall tag design and implementation. David Small designed the question displays and buckets for the programming kiosks. David Shaffer suggested the idea for the sorted bicolor LED display. Walter Bender designed the LEGO** panel name tag portion of the Thinking Tag, helped develop the final set of questions used at the anniversary event, and lent his enthusiasm to the project.

We would like to thank Linda Lowe, Susan Murphy-Bottari, John Malinowski, Felice Napolitano, Rebecca Prendergast, and Ruth Rothstein, who are members of our administrative staff, and Deborah Cohen, Director of Communications and Sponsor Relations, all of whom bought into the Thinking Tag concept in its early stages and lent their valued support and time to bring it to fruition.

Appendix: Thinking Tag implementation

Several aspects of the Thinking Tag implementation had a bearing on the final capabilities of the system, including the choice of microprocessor, infrared communications technology, and battery performance. The Thinking Tag needed to be small (the size of a normal name tag), lightweight, and cheap (under \$20 each).

The Microchip PIC16C84 microprocessor was chosen as the “brain” of the Thinking Tag for the following reasons:

- Internal, reprogrammable EEPROM (electrically erasable programmable read-only memory) made it easy to change the program of the chip.

- High-current output drivers enabled the display LEDs and infrared communications LED to be powered directly.
- Fast processing rate and interrupt capability allowed the implementation of infrared communications modulation and decoding in software.
- The chip was small and low in cost.

Infrared communication. A commercial television/videocassette recorder infrared demodulator (the Sharp IS1U60) was adopted along with an implementation of the Sony consumer infrared broadcast protocol. Although modest in communications bandwidth (the effective data rate was about 600 baud), it was deemed adequate for the modest intertag communications needs. The technology is low cost and easily driven by microprocessor designs.

The communications scheme measured time between infrared bursts to encode a start bit (3 milliseconds), a one bit (1.8 milliseconds), or a zero bit (1.2 milliseconds). After each start bit, exactly eight data bits were transmitted, making it easy to detect interference if the final bit pulse did not fall on an exact 1.2 or 1.8 millisecond boundary.

Frequent noise spikes were generated on the infrared demodulator in the presence of direct or ambient sunlight or bright halogen light, rendering communication impossible. The error detection scheme worked quite well, however, under indoor fluorescent light.

Experimentation with the strength of the transmitted signal was done to optimize the communications range. With no current-limiting resistor, prototype tags could easily transmit 20 feet or more. A 220-ohm resistor in series with the infrared output LED was selected, which limited the range of the tags to about five feet.

Software. The most interesting part of the software was the algorithm that allowed tags to communicate without interfering with one another (since infrared communication is inherently half-duplex). The strategy employed was as follows:

- If a tag received another’s transmission, it replied with its own bits after a pseudorandom 1- to 63-millisecond delay. This allowed two tags facing one other to get into a rapid “call-answer” loop.
- In the absence of another tag’s transmission, each tag broadcast its own bits every 300 milliseconds (plus the 1- to 63-millisecond pseudorandom delay to prevent synchronization problems).

Figure 3 Thinking Tag printed circuit board layout

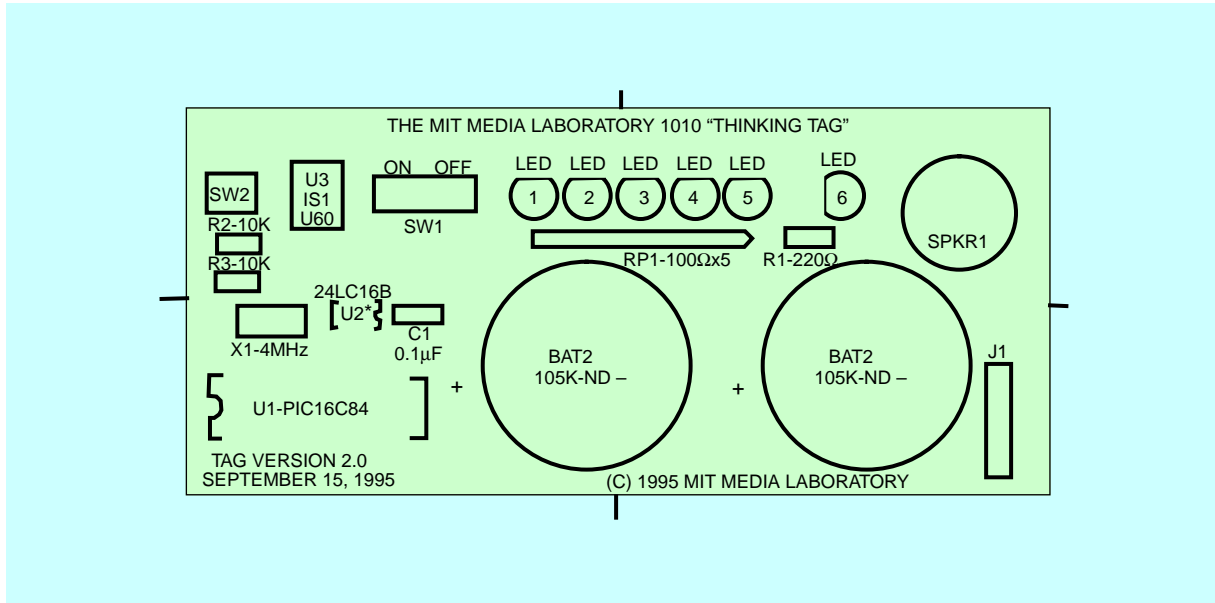

Hardware. Figure 3 shows the printed circuit board layout of the Thinking Tag design. The external EEPROM was not used, but it was left in the design for future applications (e.g., keeping track of interactions). Users' tags did not have the push-button switch or beeper.

The circuit board layout of the user tag was also used for the bucket programming stations. To set up the bucket device, the push-button switch put the bucket device into a program mode. When in this mode, it accepted an infrared code (transmitted to it from a Sony television remote) that it used afterward to program user tags. When a user dunked a tag into the bucket, the beeper of the bucket provided audible feedback to confirm successful programming of the tag.

The power supply consisted of two 3-volt coin cells (CR2032) wired in series. The batteries were rated for a maximum of 15 milliamperes of current drain; however, while the display LEDs were powered, twice this current was drawn, depressing their voltage to around 4 volts. The Sharp IS1U60 infrared demodulator was the only component affected by this voltage dip, but it was actually disabled by the out-of-spec voltage supply, and the tag was unable to detect infrared while it was displaying information on its visible LEDs.

This problem was resolved by having the tag display information *during its transmit cycle* after having just received a transmission from another tag. During the transmit cycle, it could not receive data anyway, so it was the ideal time to perform an action that otherwise would disable infrared reception. This alternation between the receive and transmit/display modes caused two communicating tags to alternately blink their displays in a pleasing manner.

**Trademark or registered trademark of LEGO Systems, Inc.

Cited references

1. A. Bruckman and M. Resnick, "The MediaMOO Project: Constructionism and Professional Community," *Convergence* **1**, No. 1, 94–109 (1995).
2. M. Stefik, G. Foster, D. G. Bobrow, K. Kahn, S. Lanning, and L. Suchman, "Beyond the Chalkboard: Computer Support for Collaboration and Problem Solving in Meetings," *Communications of the ACM* **30**, No. 1, 32–47 (1987).
3. R. Want, A. Hopper, V. Falcao, and J. Gibbons, "The Active Badge Location System," *ACM Transactions on Information Systems* **10**, No. 1, 91–102 (1992).
4. B. Sheth and P. Maes, "Evolving Agents for Personalized Information Filtering," *Proceedings of the Ninth IEEE Conference on Artificial Intelligence for Applications* (1993), pp. 345–352.
5. P. Chesnais, M. Mucklo, and J. Sheena, "The Fishwrap Personalized News System," *IEEE Second International Workshop on Community Networking* (1995), pp. 275–282.
6. S. Elo, "Augmenting Text: Good News on Disasters," *DAGS95*:

Electronic Publishing and the Information Superhighway (1995).

7. D. A. Norman, *The Psychology of Everyday Things*, Basic Books, New York (1988), p. 102.

Accepted for publication May 10, 1996.

Rick Borovoy *MIT Media Laboratory, 20 Ames Street, Cambridge, Massachusetts 02139-4307 (electronic mail: borovoy@media.mit.edu)*. Mr. Borovoy graduated from Harvard University with a B.A. in computer science. He then worked for five years at Apple Computer, where he did research on technology for learning in social contexts. He is currently pursuing a master's degree in the Epistemology and Learning Group at the MIT Media Lab, where he continues to explore the relationship between technology, communication, and learning.

Michelle McDonald *MIT Media Laboratory, 20 Ames Street, Cambridge, Massachusetts 02139-4307 (electronic mail: mcdonald@media.mit.edu)*. Ms. McDonald is pursuing a master's degree in media arts and sciences at the Media Lab. She graduated with a B.S. in computer science from the Massachusetts Institute of Technology in 1995.

Fred Martin *MIT Media Laboratory, 20 Ames Street, Cambridge, Massachusetts 02139-4307 (electronic mail: fredm@media.mit.edu)*. Dr. Martin earned a B.S. degree in computer science in 1986, an M.S. in mechanical engineering in 1988, and a Ph.D. in media arts and sciences in 1994, all from the Massachusetts Institute of Technology. His doctoral dissertation explored learning in an intensive, design-rich robot-building class he codeveloped for MIT undergraduates. Dr. Martin's research interests include: the role of experiential knowledge in learning formal scientific and engineering methods; design-rich environments for learning; and robots as a medium for exploring engineering practice. He is presently a research scientist with the Epistemology and Learning Group at the MIT Media Laboratory.

Mitchel Resnick *MIT Media Laboratory, 20 Ames Street, Cambridge, Massachusetts 02139-4307 (electronic mail: mres@media.mit.edu)*. Dr. Resnick, an associate professor at the MIT Media Laboratory, studies the role of new technological tools in learning and education. He has helped develop a variety of "computational construction kits" (including LEGO/Logo and StarLogo), and he cofounded the Computer Clubhouse, an afterschool learning center for youth from under-served communities. He earned a B.A. in physics at Princeton University, and M.S. and Ph.D. degrees in computer science at MIT. He won a National Science Foundation Young Investigator Award in 1993, and he is author of the book *Turtles, Termites, and Traffic Jams*, published by MIT Press. Dr. Resnick is on the Board of Overseers and is chair of the education committee at The Computer Museum.

Reprint Order No. G321-5619.